



Atlas Workholding 2/3 Jaw Thru-Hole Power Chuck

PAFH 8" - 24" Chucks

- ⊕ Used as 2 jaw or 3 Jaw Power Chuck
- ⊕ Thru-hole and long stroke
- ⊕ Adapter mounted
- ⊕ Serration Pitch 1.5mm 8", 10" & 12" - 3mm 15"
- ⊕ Larger diameters available

Model No.	Jaw Stroke Dia	Sleeve Stroke	Gripping Dia.		Maximum Pull		Max Grip		Max RPM	Wt lbs
			2 Jaw Max	3 Jaw Min	2 Jaw lbs	3 Jaw lbs	2 Jaw lbs	3 Jaw lbs		
PAFH8-A5	.378"	.709"	7.87	1.181	3,306	4,409	7,275	9,700	3000	44
PAFH8-A6	.378"	.709"	7.87	1.181	3,306	4,409	7,275	9,700	3000	44
PAFH10-A6	.728"	.984"	9.84	1.181	5,070	7,716	9,038	13,668	3000	70
PAFH10-A8	.728"	.984"	9.84	1.181	5,070	7,716	9,038	13,668	3000	70
PAFH12-A8	.803"	1.102"	11.81	1.967	6,613	9,920	11,684	17,636	2500	121
PAFH12-A11	.803"	1.102"	11.81	1.967	6,613	9,920	11,684	17,636	2500	121
PAFH15-A8	.803"	1.102"	13.78	2.756	8,818	13,227	15,652	23,148	2000	218
PAFH15-A11	.803"	1.102"	13.78	2.756	8,818	13,227	15,652	23,148	2000	218

Also available in 18", 21" and 24", contact factory.

Dimensional Data (in inch)

MODEL	PAFH-8	PAFH-10	PAFH-12	PAFH-15
A	8.26	10	11.97	15
B	2.874	3.346	3.819	4.803
C	7.480	9.055	11.024	13.760
F	.197	.197	.197	.276
H	5.250	6.750	7.874	9.843
J	1.378	1.575	2.165	2.953
K	6-M12	6-M16	6-M20	6-M20
L	.787	.866	.984	1.063
M	.984	1.181	1.181	1.969
N max.	1.803	2.020	2.891	3.378
N min	1.614	1.661	2.189	2.976
O max.	1.181	1.654	1.831	2.608
O min	.295	.374	.413	.591
P max.	.827	0	0	0
P min	.118	-.984	-1.102	-1.102
Q	1.181	1.378	1.575	1.575
R	.475	.630	.630	.826
S	1.063	1.102	1.181	1.575
T	M42	M50	M65	M85
U	.197	.197	.197	.197
V	1.890	2.283	2.953	3.740

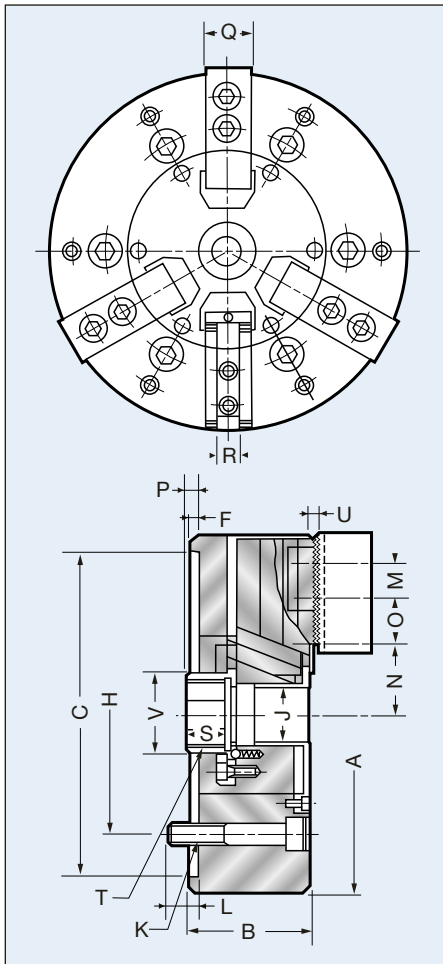

HOW TO ORDER: State quantity, Model Number of chuck and shipping instructions.