



Atlas Workhold 4 Jaw Universal Power Chuck

4ATL 8", 10", 12", 15", 18" & 24" Chucks

- Ⓜ All steel body
- Ⓜ Hardened jaw way and internal parts
- Ⓜ ± .0005 repeatability
- Ⓜ 1.5mm x 60° master jaws
- Ⓜ 4-Jaw universal design

Model No.	Through Hole	Plunger Stroke	Jaw Stroke	Max Draw Bar Pull Force lb/f	Max. Gripping Force lb/f	Max Operating Pressre psi	Max RPM [Ⓜ]	Wt lbs	Moment of Inertia I (kg-m2)
4ATL6-A6	1.771"	.472"	.216"	4,945	12,813	405	4500	30	0.058
4ATL8-A5	2.047"	.629"	.291"	7,844	20,007	377	3600	53	0.177
4ATL8-A6	2.047"	.629"	.291"	7,844	20,007	377	3600	53	0.177
4ATL10-A6	2.952"	.748"	.346"	9,667	24,932	391	3200	79	0.324
4ATL10-A8	2.952"	.748"	.346"	9,667	24,932	391	3200	79	0.324
4ATL12-A6	3.582"	.905"	.417"	12,813	33,047	391	2700	129	0.763
4ATL12-A8	3.582"	.905"	.417"	12,813	33,047	391	2700	129	0.763
4ATL12-A11	3.582"	.905"	.417"	12,813	33,047	391	2700	129	0.763
4ATL15-A8	4.625"	.905"	.417"	15,961	40,405	334	1900	251	2.331
4ATL15-A11	4.625"	.905"	.417"	15,961	40,405	334	1900	251	2.331
4ATL18-A8	4.625"	.905"	.417"	15,961	40,405	334	1500	269	3.2
4ATL18-A11	4.625"	.905"	.417"	15,961	40,405	334	1500	269	3.2
4ATL24-A11	8.070"	1.023"	.472"	20,232	52,604	376	1000	582	14.5
4ATL24-A15	8.070"	1.023"	.472"	20,232	52,604	376	1000	582	14.5

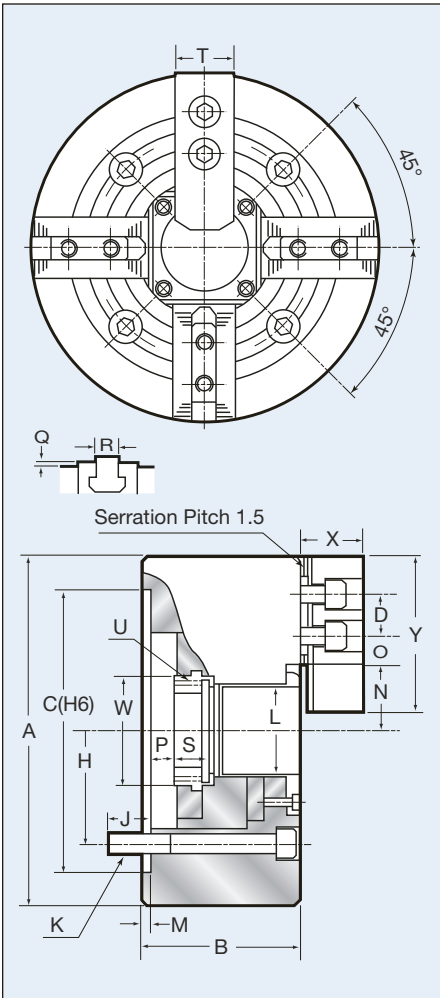

Dimensional Data (in inch)

MODEL	4ATL6	4ATL-8	4ATL-10	4ATL-12	4ATL-15	4ATL-18	4ATL-24
A	6.65	8.26	10	11.96	15	17.71	24
B	3.18	3.58	3.93	4.33	5.23	5.23	5.78
C (H6)	5.51	6.69	8.66	8.66	11.81	11.81	20.47
D	.787	.984	1.181	1.181	1.692	1.692	2.362
H	4.125	5.25	6.75	6.75	9.251	9.251	18.251
J	.629	.787	.866	.905	1.377	1.377	1.377
K	4-M10x80	4-M12x90	4-M16x100	4-M16x110	4-M20x135	4-M20x135	8-M24x150
L	1.771	2.047	2.952	3.582	4.625	4.625	8.070
M	.196	.196	.196	.236	.236	.236	.236
N max.	1.259	1.523	2.007	2.413	3.22	3.22	5.507
O max.	.895	1.171	1.328	1.801	1.781	3.139	3.444
min	.364	.580	.561	.620	.600	.600	.945
P max.	.433	.570	.334	.314	.275	.275	.630
min	-.039	-.059	-.413	-.590	-.630	-.630	-.393
Q	.078	.078	.078	.078	.196	.196	.196
R	.472	.551	.629	.826	.866	.866	.984
S	.748	.807	.984	1.102	1.692	1.162	1.496
T	1.220	1.377	1.574	1.968	2.440	2.440	2.559
U max	M55x2	M60x2	M85x2	M100x2	M130x2	M130x2	M215x3
W	2.362	2.598	3.700	4.251	5.472	5.472	9.055
X	1.456	1.496	1.692	2.007	2.598	2.598	2.874
Y	2.874	3.740	4.330	5.118	6.496	6.496	7.086

HOW TO ORDER: State quantity, Model Number of chuck and shipping instructions.