

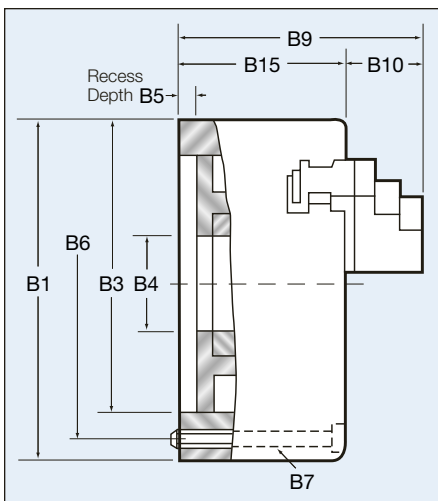

Atlas Workholding Self-Centering 3-Jaw Universal Iron Body Chucks

Series 342 Medium-Duty Value Line Flatback, D and A Type Mounting: Sizes 5" thru 25"

- ⊕ High value and lower cost
- ⊕ One year warranty
- ⊕ Standard chuck sizes 5" Thru 25"
- ⊕ Maximum .003" TIR using nominating pinion - thru 12"
- ⊕ .001" Repeatability using nominating pinion - thru 12"
- ⊕ Two-piece American Standard tongue and groove jaws
- ⊕ Hardened scroll
- ⊕ Three hardened pinions
- ⊕ Semi steel bodies



Chuck Size	Flatback Chuck No.	Type D Spindle		Type A Spindle	
		Size	Chuck No.	Size	Chuck No.
5"	0534-2000		-----		-----
6"	0634-2000	D-4	0634-20D4	A-4	0634-20A4
6"	-----		-----	A-5	0634-20A5
8"	0834-2000	D-4	0834-20D4		-----
8"	-----	D-5	0834-20D5	A-5	0834-20A5
8"		D-6	0834-20D6	A-6	0834-20A6
10"	1034-2000	D-5	1034-20D5	A-5	1034-20A5
10"	-----	D-6	1034-20D6	A-6	1034-20A6
10"	-----	D-8	1034-20D8	A-8	1034-20A8
12"	1234-2000	D-6	1234-20D6	A-6	1234-20A6
12"	-----	D-8	1234-20D8	A-8	1234-20A8
16"	1634-2000	D-8	1634-20D8	A-8	1634-20A8
16"	-----	D-11	1634-2D11	A-11	1634-2A11
20"	2034-2000	D-8	2034-20D8	A-8	2034-20A8
20"	-----	D-11	2034-2D11	A-11	2034-2A11
25"	2534-2000	D-8	2534-20D8	A-8	2534-20A8
25"	-----	D-11	2534-2D11	A-11	2534-2A11
25"	-----		-----	A-15	2534-2A15

Consult factory for chucks sizes larger than 25".

Dimensions for Universal Flatback Mounting Chucks with Two-piece Jaws (in/mm)

Chuck Size	B1	B3	B4	B5	B6	B7	B9	B10	B15	Max RPM
5"/125	4.92"/125	3.74"/95	1.18"/30	.157"/4	4.25"/108	(3) M-8	3.94"/100	1.65"/42	2.28"/58	3000
6"/160	6.30"/160	4.92"/125	1.77"/45	.197"/5	5.51"/140	(6) M-10	4.53"/115	1.97"/50	2.56"/65	2500
8"/200	7.87"/200	6.30"/160	2.56"/65	.197"/5	6.93"/176	(6) M-10	5.00"/127	2.05"/52	2.95"/75	2000
10"/250	9.84"/250	7.87"/200	3.15"/80	.197"/5	8.81"/224	(6) M-12	5.59"/142	2.44"/62	3.15"/80	1600
12"/315	12.40"/315	10.23"/260	3.94"/100	.236"/6	11.26"/286	(6) M-16	6.53"/166	3.15"/76	3.54"/90	1200
16"/400	15.75"/400	12.99"/330	5.12"/130	.236"/6	14.25"/362	(6) M-16	7.32"/186	3.38"/86	3.94"/100	1000
20"/500	19.68"/500	16.53"/420	8.26"/210	.236"/6	18.03"/458	(6) M-16	8.07"/205	3.54"/90	4.53"/115	800
25"/630	24.80"/630	21.45"/545	9.92"/252	.275"/7	23.07"/586	(6) M-16	8.68"/220.5	3.36"/85.5	5.31"/135	800

Note: Dimensions are for flatback chucks; for D or A mounted chucks dimension B15 will vary.

(1) Model No. 2034-2A11 and 2434-2A11 have a 6.5" thru-hole

HOW TO ORDER: State quantity, chuck number, and shipping instructions.



Atlas Workholding Self-Centering 3-Jaw Universal Steel Body Value Line Chucks

Series 333 Value Line Flatback, D and A Type Mounting: Sizes 5" thru 25"

- ⊕ High value and lower cost
- ⊕ One year warranty
- ⊕ Standard chuck sizes 5" thru 25"
- ⊕ Maximum .003" TIR using nominating pinion - thru 12"
- ⊕ .001" Repeatability using nominating pinion - thru 12"
- ⊕ Two-piece American Standard tongue and groove jaws
- ⊕ Hardened scroll
- ⊕ Three hardened pinions
- ⊕ Steel bodies

Manual Chucks with Mounting Plates

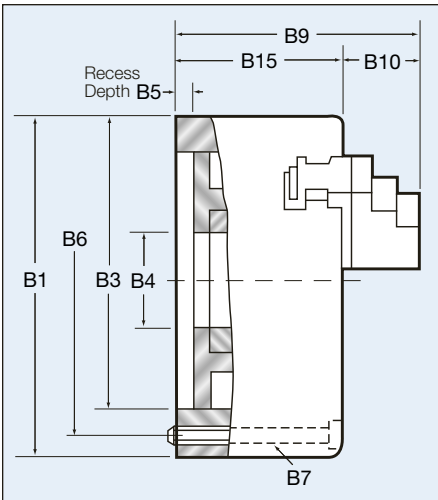

Chuck Size	Flatback Chuck No.	Type D Spindle Size	Chuck No.	Type A Spindle Size	Chuck No.
5"	0533-3000		-----		-----
6"	0633-3000	D-4	0633-30D4	A-4	0633-30A4
6"	-----		-----	A-5	0633-30A5
8"	0833-3000	D-4	0833-30D4		-----
8"	-----	D-5	0833-30D5	A-5	0833-30A5
8"	-----	D-6	0833-30D6	A-6	0833-30A6
10"	1033-3000	D-5	1033-30D5	A-5	1033-30A5
10"	-----	D-6	1033-30D6	A-6	1033-30A6
10"	-----		-----	A-8	1033-30A8
12"	1233-3000	D-6	1233-30D6	A-6	1233-30A6
12"	-----	D-8	1233-30D8	A-8	1233-30A8
16"	1633-3000	D-8	1633-30D8	A-8	1633-30A8
16"	-----	D-11	1633-3D11	A-11	1633-3A11
20"	2033-3000	D-8	2033-30D8	A-8	2033-30A8
20"	-----	D-11	2033-3D11	A-11	2033-3A11
25"	2533-3000	D-8	2533-30D8	A-8	2533-30A8
25"	-----	D-11	2533-3D11	A-11	2533-3A11

Consult factory for chucks sizes larger than 25".

Dimensions for Universal Flatback Mounting Chucks with Two-piece Jaws (in/mm)

Chuck Size	B1	B3	B4	B5	B6	B7	B9	B10	B15	Max RPM
5"/125	4.92"/125	3.74"/95	1.18"/30	.157"/4	4.25"/108	(3) M-8	3.94"/100	1.65"/42	2.28"/58	4300
6"/160	6.30"/160	4.92"/125	1.77"/45	.197"/5	5.51"/140	(6) M-10	4.53"/115	2.57"/50	2.56"/65	4500
8"/200	7.87"/200	6.30"/160	2.56"/65	.197"/5	6.93"/176	(6) M-10	5.00"/127	2.05"/52	2.95"/75	4000
10"/250	9.84"/250	7.87"/200	3.15"/80	.197"/5	8.81"/224	(6) M-12	5.59"/142	2.44"/62	3.15"/80	3000
12"/315	12.40"/315	10.23"/260	3.94"/100	.236"/6	11.26"/286	(6) M-16	6.53"/166	3.15"/76	3.54"/90	2300
16"/400	15.75"/400	12.99"/330	5.12"/130	.236"/6	14.25"/362	(6) M-16	7.32"/186	3.38"/86	3.94"/100	2000
20"/500	19.68"/500	16.53"/420	8.26"/210	.236"/6	18.03"/458	(6) M-16	8.07"/205	3.54"/90	4.52"/115	1200
25"/630	24.80"/630	21.45"/545	9.92"/252	.275"/7	23.07"/586	(6) M-16	8.68"/220.5	3.36"/85.5	4.52"/135	1200

Note: Dimensions are for flatback chucks; for D or A mounted chucks dimension B15 will vary.

HOW TO ORDER: State quantity, chuck number and shipping instructions.